

1 CORPORATE OVERVIEW



A global company
built on
innovative brands

1 GERFLOR AT ONE GLANCE

FOCUS

Resilient flooring
Wall covering
Finishes

**Innovative,
Decorative,
Sustainable &
Specialty-based**
solutions

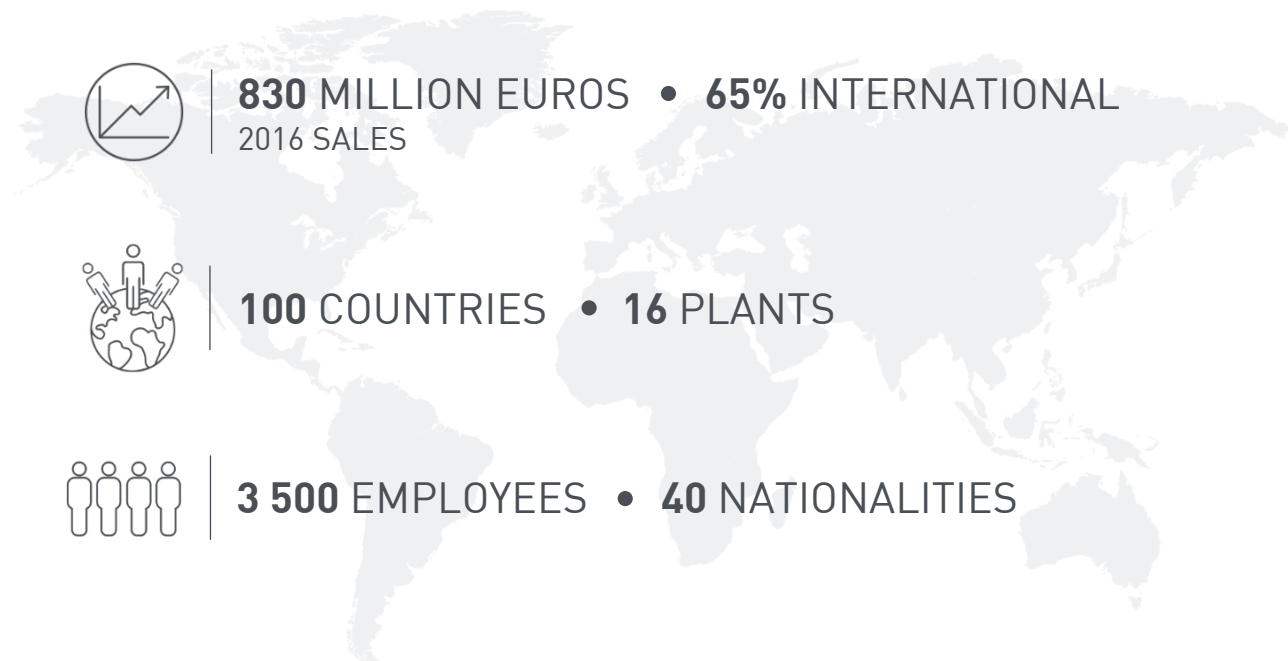

830 MILLION EUROS • **65% INTERNATIONAL**
2016 SALES



100 COUNTRIES • **16 PLANTS**



3 500 EMPLOYEES • **40 NATIONALITIES**

1.1 KEY FIGURES

SALES GROWTH

A steady growth based on organic development and on acquisitions

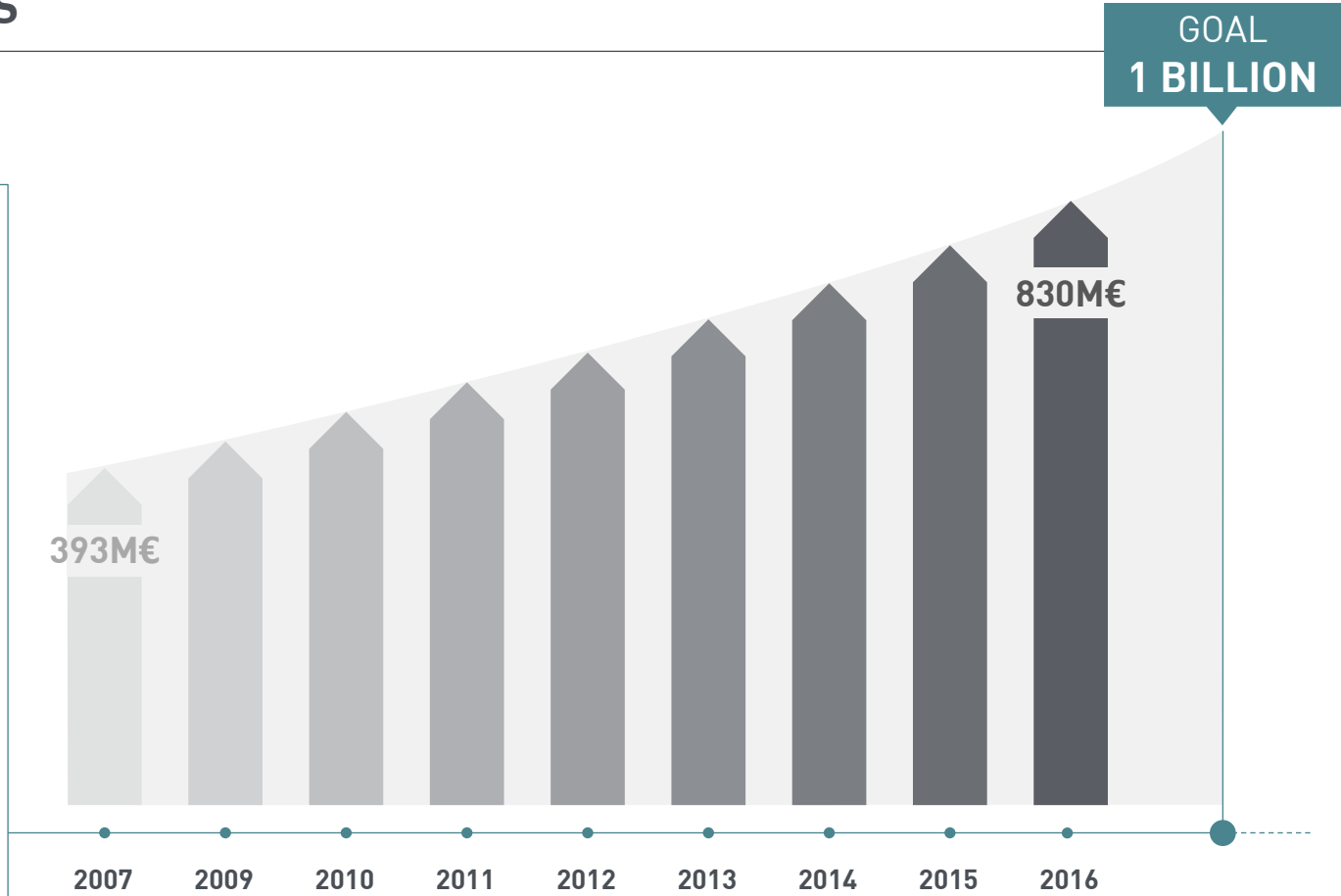

1.2 A GROUP BUILT ON INNOVATIVE BRANDS AND COMPANIES

GERLAND SOLS

Invention of self adhesive tiles – 1st LVT



1925

1937

1947



MIPOLAM

The first homogeneous flooring



TARAFLEX

Supplier to the Olympic games for 40 years



2006



GERFLOR CHINA

Manufacturing - greenfield

SPM

Leader in Wall Protection



2008



BOIDE SCANDI

Flooring distribution

ROMUS

Tools, profiles and entrance mats



2011



AFS USA

Flooring distribution

CSCI

The NBA parquet & founder of backyard sport Courts



2012



BCIC KSA

Vinyl Tiles Manufacturer

GRADUS

The first solution for barrier matting



2014

2015



STEP'STYLE CZ REP

Flooring distribution

1.3 GLOBAL PRESENCE



25
SUBSIDIARIES

16
MANUFACTURING
PLANTS
AND LOGISTIC
HUBS

5
TECHNOCENTRES

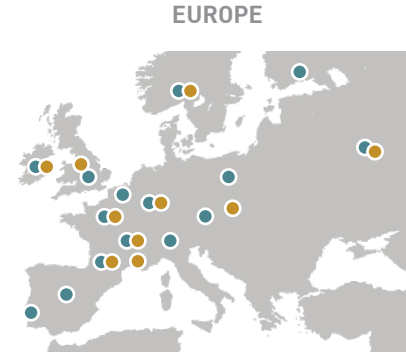
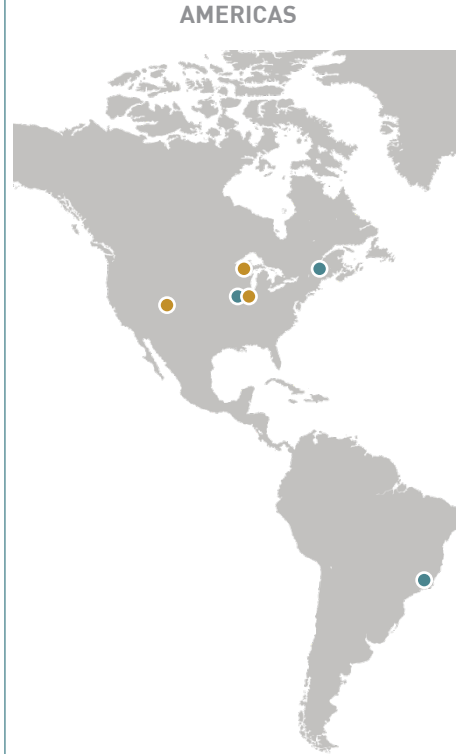
AND A BROAD
NETWORK
OF DISTRIBUTORS



-  Sales office
-  Manufacturing plant or logistic hub

1.3 PRODUCTION FACILITIES - EMEA

Manchester, UK



300



Carrickmacross, IRELAND



30



Paris, FRANCE



100



Tarare, FRANCE



650



Toulouse, FRANCE



60



Provence, FRANCE



650



EUROPE



MIDDLE EAST & AFRICA



Troisdorf, GERMANY



190



Dammam, SAUDI ARABIA



120



1.3 PRODUCTION FACILITIES – AMERICA / ASIA

AMERICAS

Amasa, USA



140



Salt Lake City, USA



110



ASIA PACIFIC

Changshu, CHINA



185



1.3 PRODUCTION FACILITIES – EMEA

France

TARARE

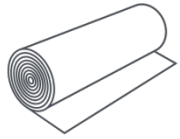

650



1 R&D LAB

1 TECHNOCENTRE

5 INDUSTRIAL PROCESSES

- Calendering
- Pressing
- Coating
- Laminating
- Water jet cutting



1.3 PRODUCTION FACILITIES – EMEA

France

PROVENCE

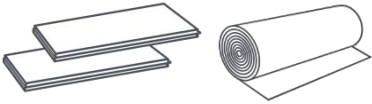

650



1 DESIGN CENTER

1 R&D LAB

4 INDUSTRIAL PROCESSES

- Calendering
- Coating 2 & 4 m
- Printing
- Pressing

1 LOGISTIC HUB



1.3 PRODUCTION FACILITIES – EMEA

France

TOULOUSE



Wall protection, handrails
innovative and eco-
responsible solutions for
Healthcare, Education ,
Sport and Cleanrooms.



60



- 3 PROCESSES**
- Product Design
 - Extrusion
 - Water jet cutting



1.3 PRODUCTION FACILITIES – EMEA

France

PARIS

ROMUS[®]

Entrance mats, Tools,
Accessibility and Profile
solutions for flooring and
wall professionals



100



1.3 PRODUCTION FACILITIES – EMEA

United Kingdom

MANCHESTER

GRADUS

Stair edging & floor trims,
Barrier matting system,
Wall protection, Lighting
solutions, Carpet tiles



300



3 PLANTS

- Profiles extrusion
- Entrance matting assembling
- Carpet weaving



1.3 PRODUCTION FACILITIES – EMEA

Germany

TROISDORF

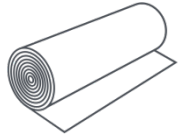

190



1 R&D LAB

1 INDUSTRIAL
PROCESS

- Pressing



1.3 PRODUCTION FACILITIES – EMEA

Saudi Arabia

DAMMAM

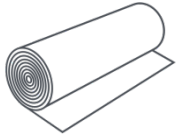

120



4 INDUSTRIAL PROCESSES

- Calendering
- Skirting
- Dry mixing
- Liquid adhesives



1.3 PRODUCTION FACILITIES – EMEA

Ireland

CARRICK-MACROSS

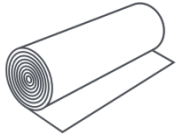

30



3 INDUSTRIAL PROCESSES

- Calendering
- Coating
- Pressing



1.3 PRODUCTION FACILITIES – AMERICAS

USA

AMASA



CONNOR SPORTS
Where Champions Play™

Design and Manufacturing
of hardwood sports flooring



140



4 INDUSTRIAL
PROCESSES

- Cutting
- Machining
- Assembling
- Finishing



1.3 PRODUCTION FACILITIES – AMERICAS

USA

SALT LAKE CITY



Design and Manufacturing of modular sports floors for outdoor and indoor surfaces



110



1 R&D LAB

3 INDUSTRIAL PROCESSES

- Mold injection
- Film lamination
- Varnishing



1.3 PRODUCTION FACILITIES – Asia

China

CHANGSHU

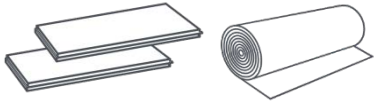

185



1 R&D LAB

1 TECHNOCENTRE

2 INDUSTRIAL PROCESSES

- Calendering
- Lamination



1.4 PRODUCTION TECHNOLOGIES – VINYL FLOORING

- OPERATIONAL EXCELLENCE
- PROCESS INNOVATION
- CONTINUOUS INVESTMENT



CALENDERING



PRESSING



COATING



LAMINATION



SURFACE TREATMENT



PRINTING



WATER JET CUTTING

1.4 CALENDERING

BENEFITS

- Regularity of thickness
- Permanence of design
- Durability of product
- Authenticity of colours

Production of sheets or films for surfaces, interlayers, backing or pellets.

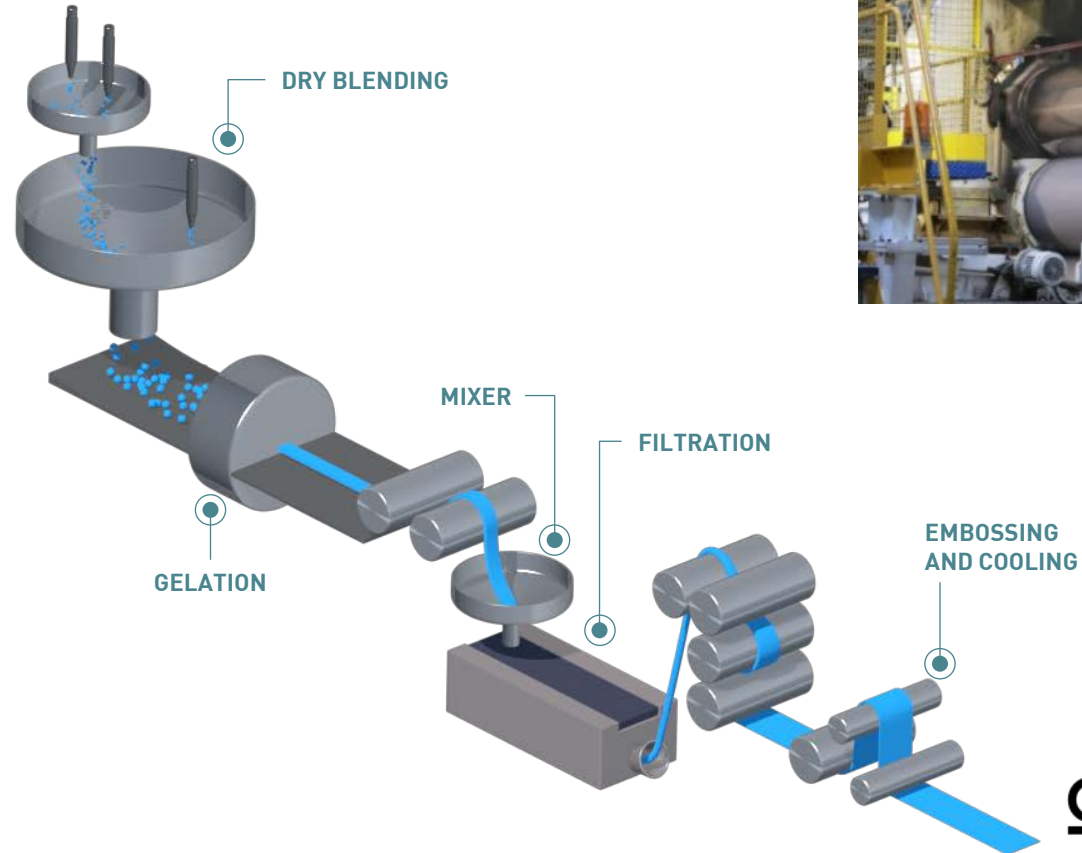

1.4 PRESSING

BENEFITS

- Design within the whole thickness of the product: durability, long life
- ProtecSol® 2 surface treatment: easy maintenance / stain resistance
- Only by GERFLOR

Pressing of the pellets in order to achieve a uniform sheet for an "all-through design" effect.

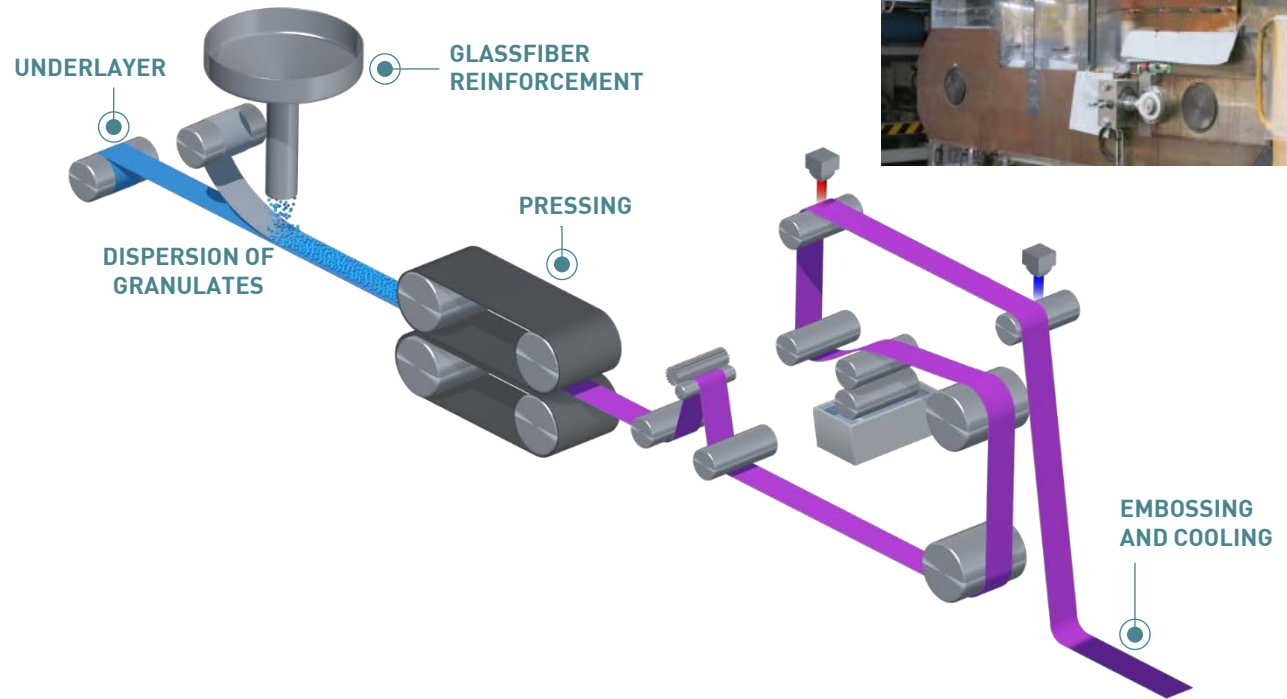
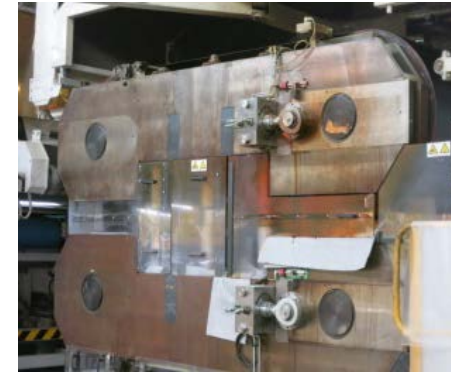

1.4 COATING

BENEFITS

- Large choice of designs
- Very high density foam + glass fibre grid: sound insulation / indentation resistance
- UV cured surface treatment: easy maintenance

Conversion of a liquid paste into a compact layer or foam.

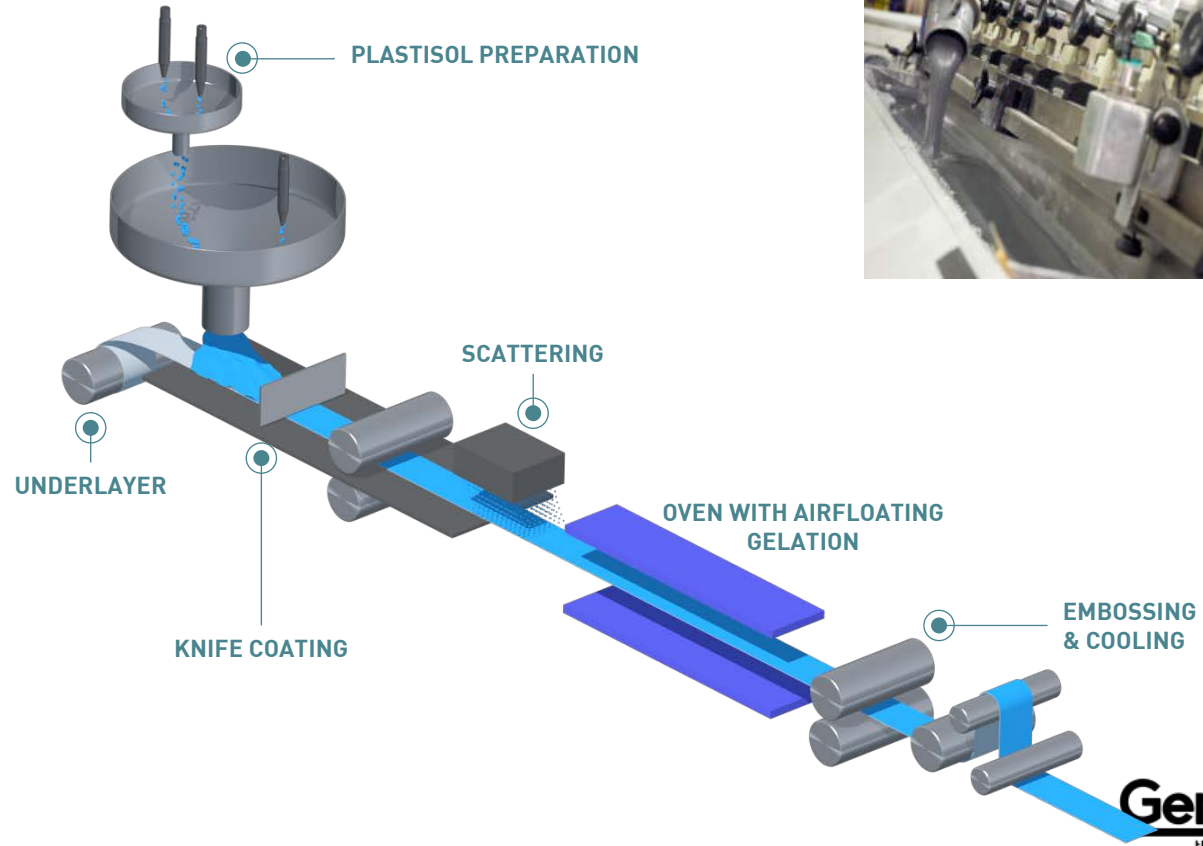

1.4 LAMINATION

Assembling of different calendered, pressed, coated or substrate layers under the action of temperature and pressure.

BENEFITS

- Most durable and reliable assembling of various layers
- Sound insulation, comfort, safety and performance, indentation and rolling resistance.
- Only by GERFLOR

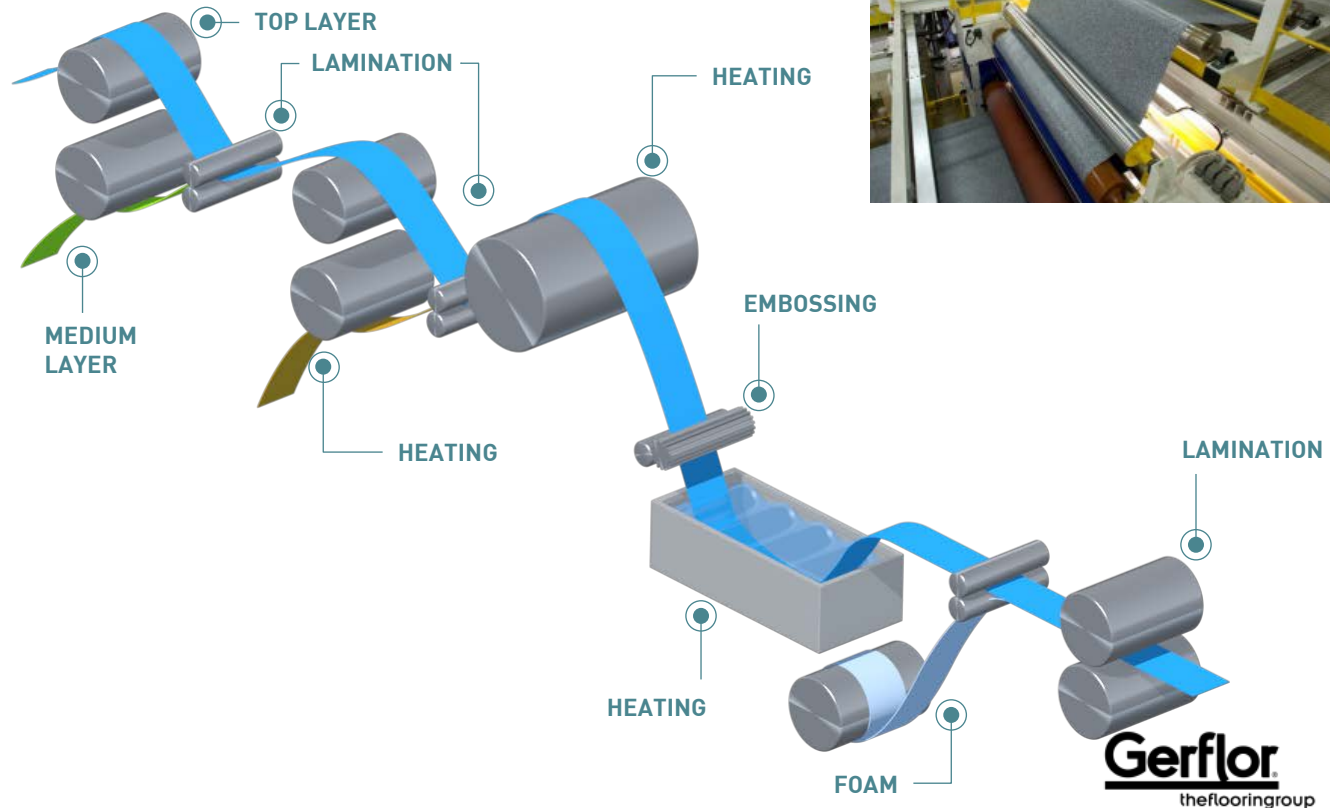

1.4 GRAVURE PRINTING

BENEFITS

- Large choice of highly precised designs
- Creativity of patterns (imitating, unique...)
- 100% solvent free (use of water based inks)
- Recycling of inks through washwater evaporation
- Cleaning of ink barrels with bio-degradable agents

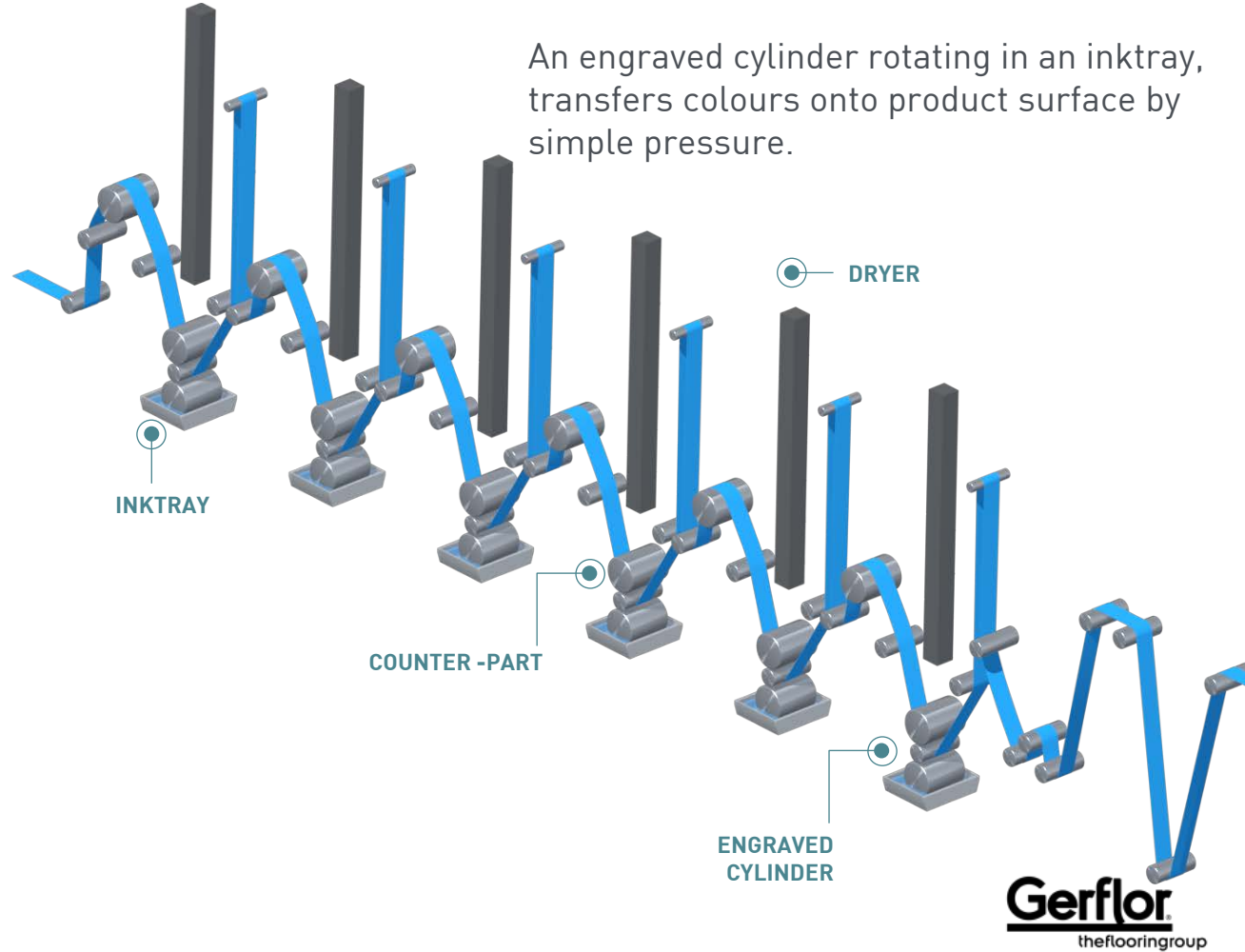

1.4 DIGITAL PRINTING

BENEFITS

- Unlimited & unique design creation: ultimate realism, customized logos, limited pattern repeat...
- Flexibility : low volume production, extreme reactivity...
- Environmental impact reduction

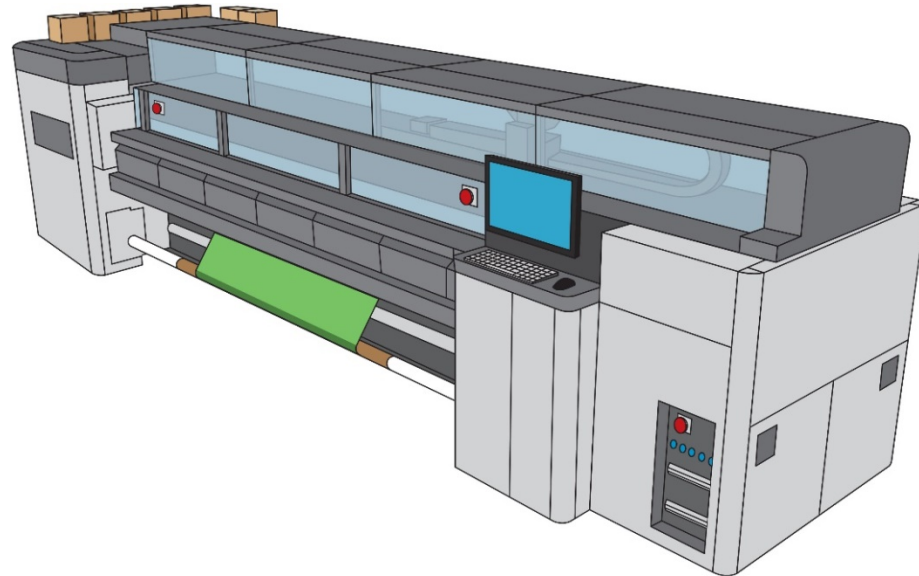

1.4 SURFACE TREATMENT

BENEFITS

- Easy clean
- Slip resistance
- No friction-burn (Sport)
- Only by GERFLOR

Application of protective treatment by electrostatic spraying and UV cross-linking.



ELECTROSTATIC SPRAYING

UV CURING

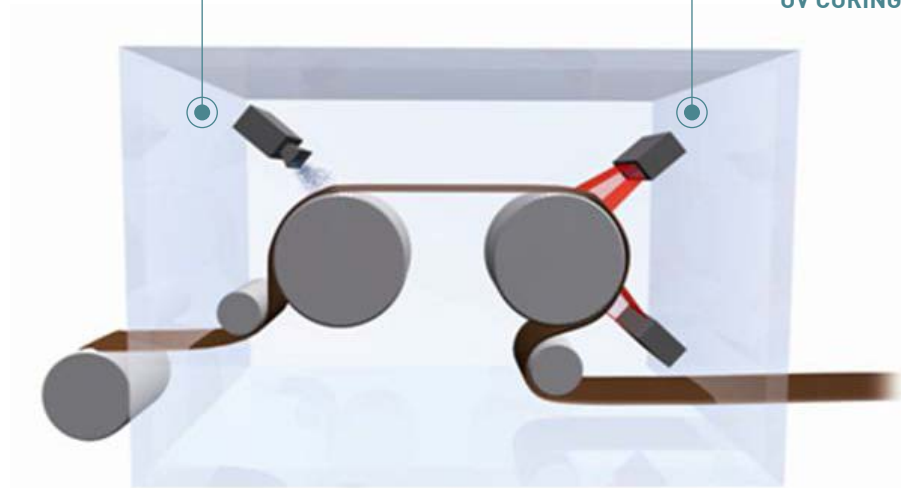

1.4 WATER JET CUTTING

BENEFITS

- Customized format for complex surfaces
- Tailor made logos and decorative patterns
- Throughout cut for an extreme durability
- Ultra precise cutting (0,2 mm) for perfect seams

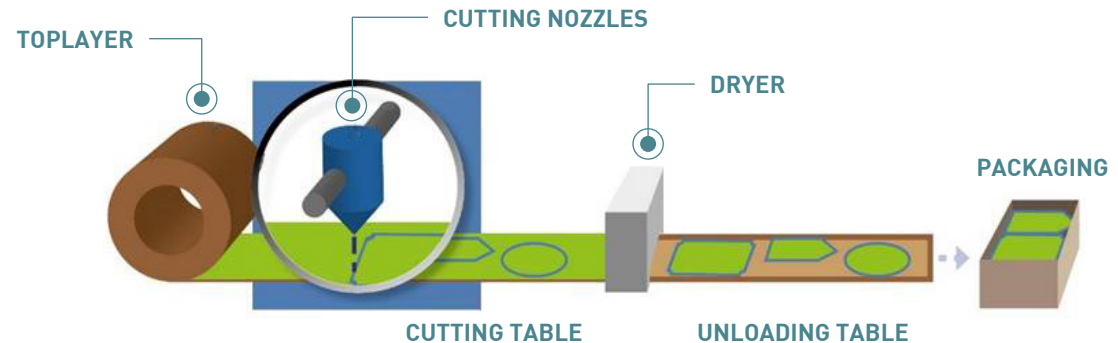

1.5 MISSION AND VALUES



VISION

In this fast-changing world, we strive to improve people's lives, by providing safe and creative flooring solutions that exceed their needs and contribute to a better world.

MISSION

Anticipate and lead the way through :

- Innovative, decorative, eco-friendly and specialty-based solutions
- A steadfast devotion to the needs and success of our customers and partners,

We will meet these challenges by our teams' passion and belief that there is always a better way.

VALUES

Teamwork

Respect & Integrity

Accountability & Commitment

Customer success

Entrepreneurship & Agility

1.5 GERFLOR VALUES AND BEHAVIORS

TEAMWORK

- We **work together**, celebrate **success and learn** from setbacks.
- We develop and **empower people**, we help others accomplish their goals.
- We seek the **success of the company** that comes before individual victories.
- We communicate **openly and proactively**.
- We believe in **project management** and functional organizations.

Teamwork

Respect & Integrity

Accountability & Commitment

Customer success

Entrepreneurship & Agility



1.5 GERFLOR VALUES AND BEHAVIORS

Teamwork

Respect & Integrity

Accountability & Commitment

Customer success

Entrepreneurship & Agility

RESPECT AND INTEGRITY

- We treat others with **respect** regardless of position or varying opinions.
- We **comply with all** internal and external **standards and regulations**.
- We strive to always act with **transparency and honesty**.
- We embrace **diversity**.
- We are quick to **recognize and rectify errors**.



1.5 GERFLOR VALUES AND BEHAVIORS

ACCOUNTABILITY AND COMMITMENT

- We work hard, we are **passionate and committed**.
- We seek **excellence and performance** over the long term.
- We take personal ownership of our **decisions and actions**.
- We **prioritize** what needs to be achieved now versus what can be accomplished later.
- We **decide** and move forward even in situations of uncertainty.

Teamwork
Respect & Integrity
Accountability & Commitment
Customer success
Entrepreneurship & Agility



1.5 GERFLOR VALUES AND BEHAVIORS

Teamwork
Respect & Integrity
Accountability & Commitment
Customer success
Entrepreneurship & Agility

CUSTOMER SUCCESS

- We care deeply about **shared success with our customers.**
- We build **long-term relationships.**
- We listen well in order to **better understand** needs and trends.
- We are **problem-solvers** who deliver innovative solutions.
- We have a **positive “can do” attitude.**



1.5 GERFLOR VALUES AND BEHAVIORS

ENTREPRENEURSHIP AND AGILITY

- We are **curious** and support change.
- We are driven by **efficient ideas and actions** to generate tangible results.
- We minimize complexity and make efforts to **find practical solutions** to hard problems.
- We are ready to **take reasonable risks**.
- We are **tenacious and convinced that there is always a better way**.

Teamwork
Respect & Integrity
Accountability & Commitment
Customer success
Entrepreneurship & Agility



1.6 GROWTH STRATEGY



SEGMENT EXPERTISE



SALES & MARKETING PROFICIENCY



OPERATIONAL EXCELLENCE



INNOVATIVE SOLUTIONS



GEOGRAPHIC EXPANSION



VALUE-BASED ACQUISITIONS

2 A WORLD OF SOLUTIONS

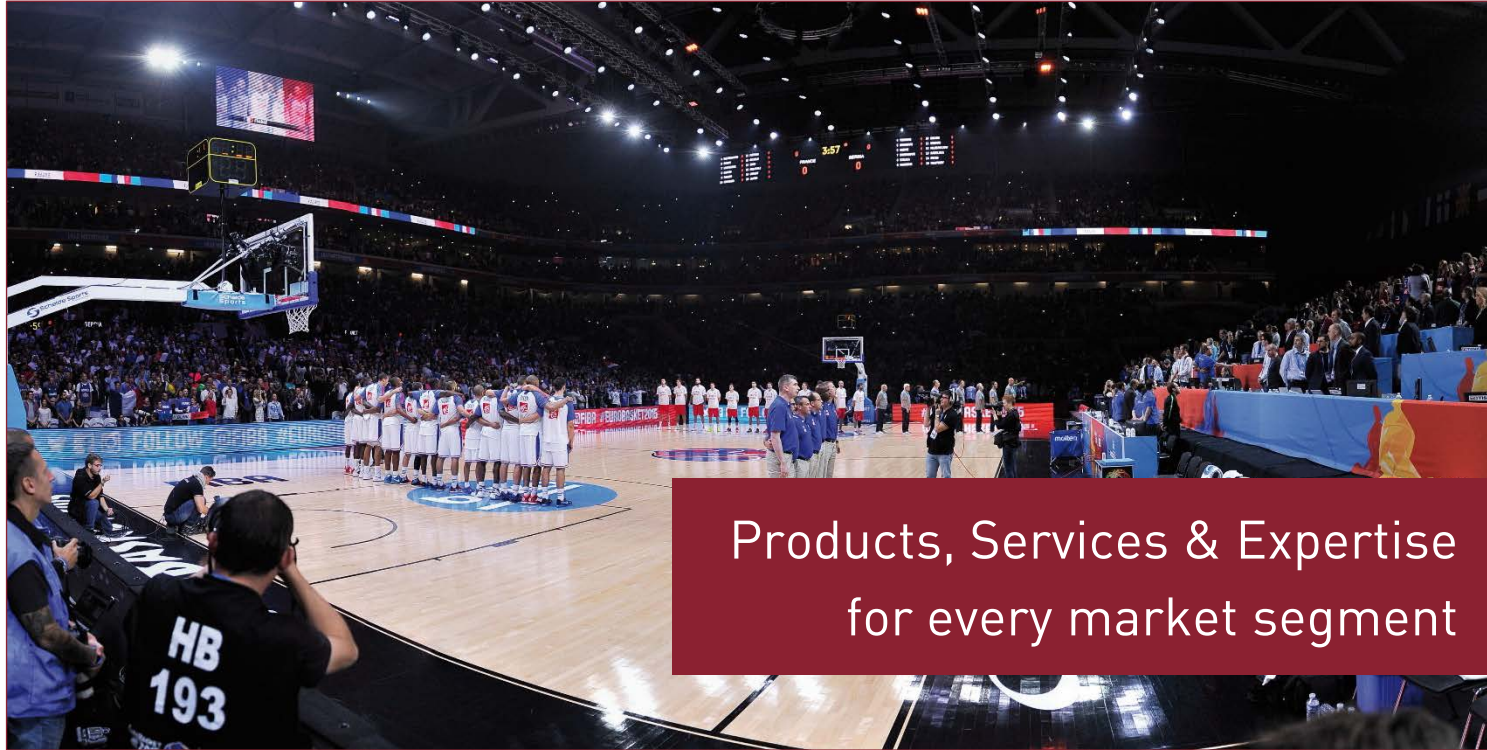

2.1 SPECIFIC SOLUTIONS FOR ALL MARKET APPLICATIONS

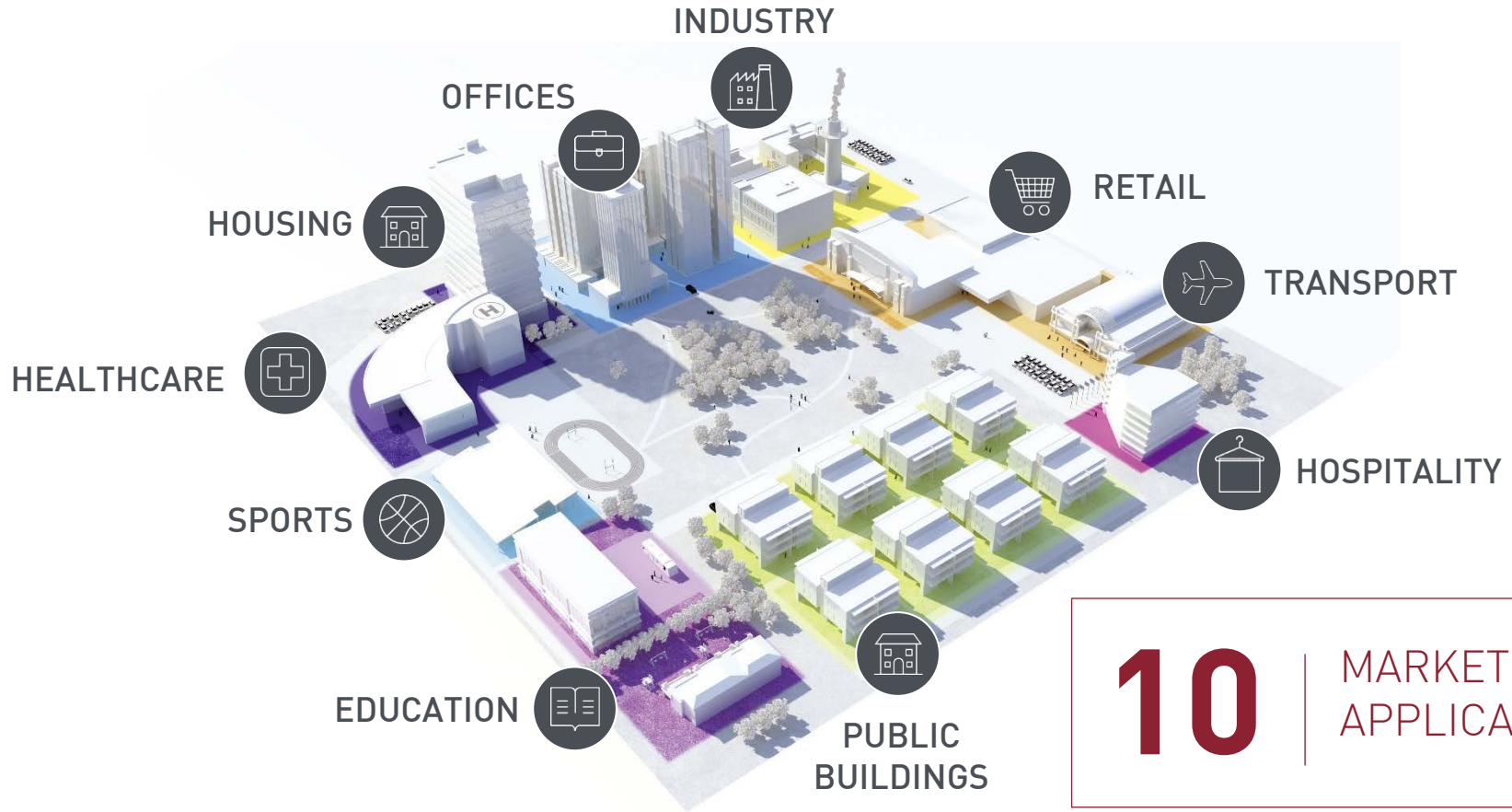

10

MARKET
APPLICATIONS

2.2 PRODUCT OFFER: THE MOST COMPREHENSIVE RANGE

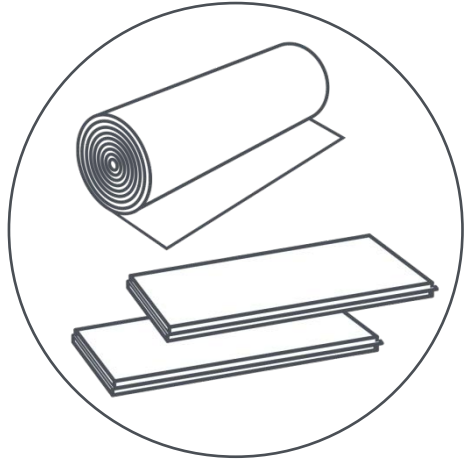

FLOORING

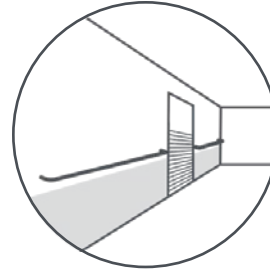

WALL

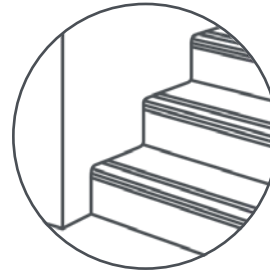

FINISHES

2.2 PRODUCT OFFER: THE MOST COMPREHENSIVE RANGE

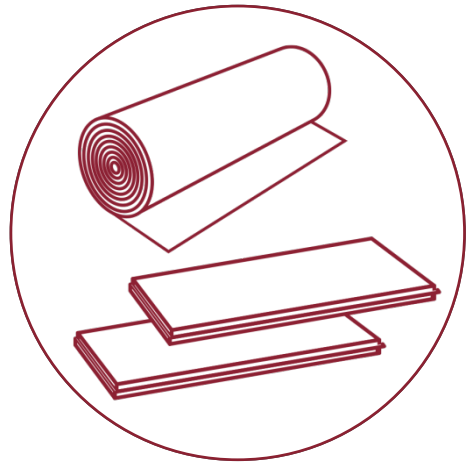

FLOORING

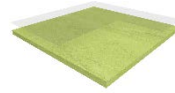

TECHNICAL ROLLS

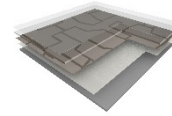

PRINTED ROLLS

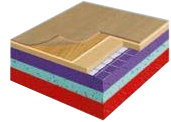
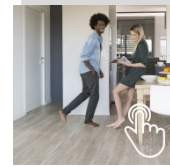

SPORT

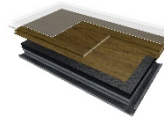
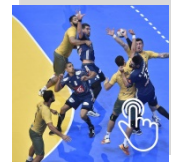

LVT

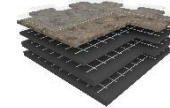

TECHNICAL TILES

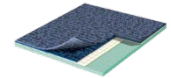

CARPET TILES

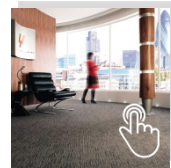

2.2 FLOORING

HOMOGENEOUS ROLLS

- The most durable and hygienic vinyl solution installed across the globe
- A strong reputation for its high traffic performance in Health & Education
- A patented surface treatment 'Evercare' for a cost effective maintenance
- Complete ESD ranges to cover any risk of electrostatic discharge

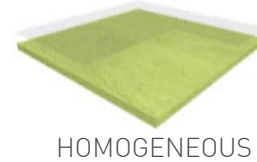

HOMOGENEOUS



ESD



TECHNICAL ROLLS

PREMIUM

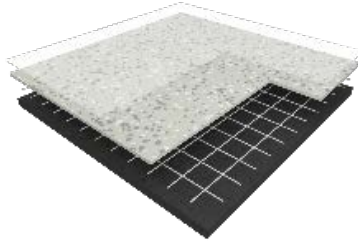

- An outstanding durability highly appreciated in the healthcare industry
- Easy maintenance & stain resistance
- Very high performance indentation/acoustic

SAFETIES

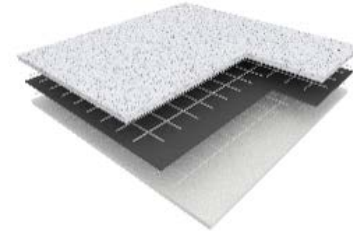

- Large choice of solutions where slip resistance is essential
- Easy cleaning & maintenance
- Enhanced colour, design & brightness

2.2 FLOORING

PRINTED ROLLS

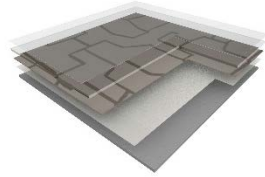

- High realism of design and large choice of designs and colors
- The best acoustic/indentation performances on the market
- Extreme stain resistance, easy maintenance

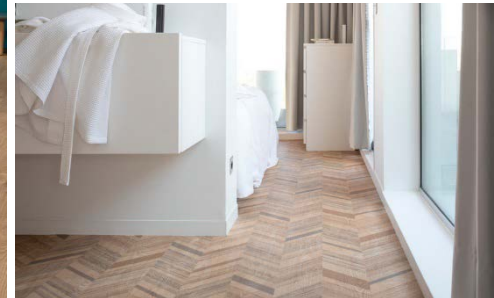

2.2 FLOORING

SPORT

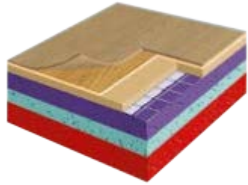

TARAFLEX®
SPORTS

- The safest floor for all users from kids to seasoned professionals.
- The highest choc absorption rate and best protection against injuries.
- The most appealing design for all kinds of facilities.
- The benchmark solution for volley ball and hand ball.



**CONNOR
SPORTS**

- Extreme durability with 20 mm solid wood strips.
- North American maple with the highest density.
- NBA & NCAA preferred floor.

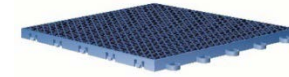

**SPORT
COURT**

- Modular free-floating tiles for indoor and outdoor.
- The easiest and fastest solution for both temporary and permanent sport venues.

2.2 FLOORING

LUXURY VINYL TILES



- The largest choice of design and colors
- An exclusive patented vertical interlocking system
- 30% faster to install than competition
- The largest production capacity in Europe



2.2 FLOORING

TECHNICAL TILES

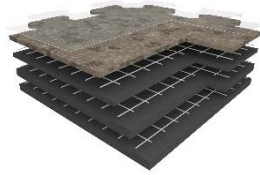

- The best and very unique solution for heavy traffic
- Very easy and quick installation on any type of hard surface up to 4 times faster than ceramic
- More than 25 years of successful installations on all markets

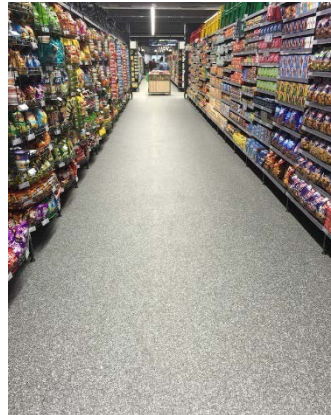

2.2 FLOORING

CARPETS

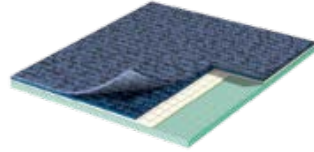

- **Wide choice of products & designs**
 - Premium carpet
 - High performance contractor carpet
 - Broadloom & impervious backed carpet
- **Wide range of applications including**
 - Commercial Office
 - Education
 - Healthcare



2.2 FLOORING

CARPETS

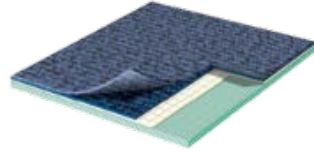

- **Combine product & design to create a coordinated scheme that balances the specific performance requirements of different areas within a building**
- **Manufactured using high performance yarn systems**
 - Comprehensive product warranties
 - Easy to clean & maintain



2.2 PRODUCT OFFER: THE MOST COMPREHENSIVE RANGE

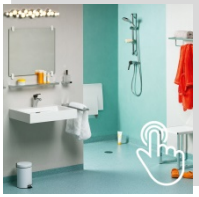

WALL
COVERING



WALL
PROTECTION

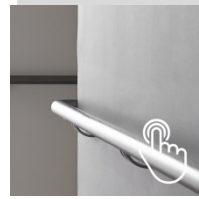

HANDRAILS

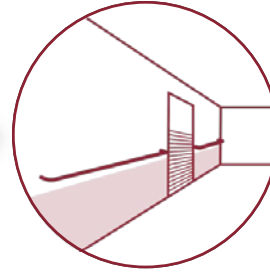

WALL

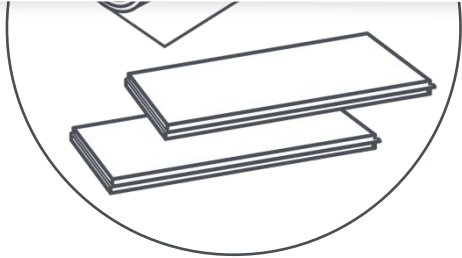

FLOORING

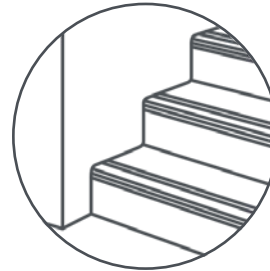

FINISHES

2.2 WALL

WALL COVERING

- Global solution Floor – Wall – Accessories
- Decorative range – several exclusive patterns
- Hygiene & easy maintenance
- Utmost fire resistance (Bs2d0)



2.2 WALL

WALL PROTECTION

- The most complete range of panels, crash-rails and corner protectors on the market
- Perfect optimization between impact resistance (320 kg at 3 km/h speed) and hygiene (chemical and stain resistant, bacteriostatic material)
- A wide range of colors and embossings
- Digital printing allowing endless and unique designs



2.2 WALL

HANDRAILS

- Ergonomically designed to ensure comfort of use
- Excellence protection against hand-borne infection (bacteriostatic materials, bactericidal joints...)
- A wide handrail product range to adapt the resistance to the solicitation of the area

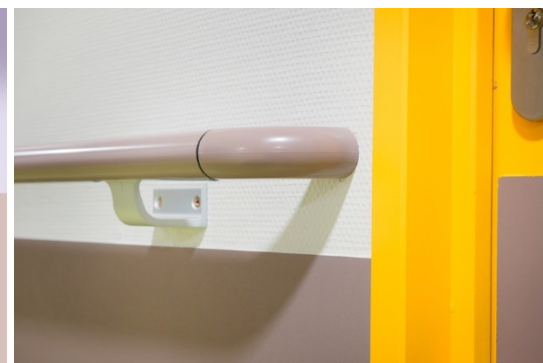

2.2 PRODUCT OFFER: THE MOST COMPREHENSIVE RANGE

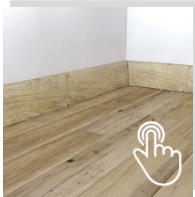

PROFILING

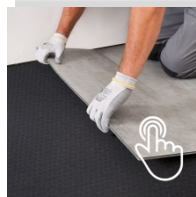

ADD ON
LAYERS

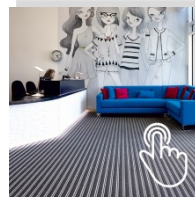

MATTING

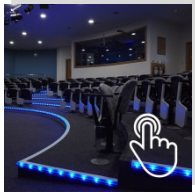

LIGHTING

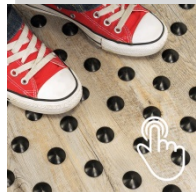

ACCESSIBILITY

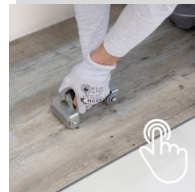

TOOLS

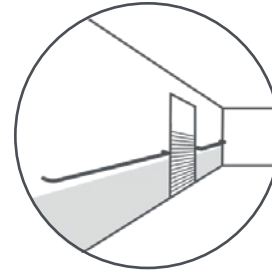

WALL

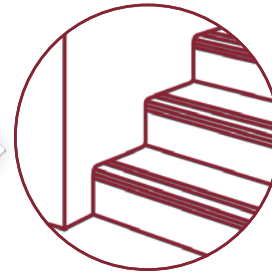

FINISHES

2.2 FINISHES

PROFILES

- Increased safety on stairs and floors
- Enhancing the aesthetics of a building
- A wide choice of shapes (stair noses, trims, skirtings...) and material (PVC, aluminium...)
- 24h delivery concept

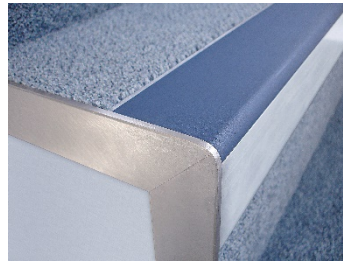

2.2 FINISHES

ADD-ON LAYERS

- Solutions to enhance acoustic comfort (in shower system or with LVT)
- High traffic resistance
- Improved ease of installation



2.2 FINISHES

MATTING

- Helps to reduce slip accidents
- Reduces maintenance costs
- Improves the appearance and durability of surrounding floorcoverings



2.2 FINISHES

LED LIGHTING

- Enhanced safety and aesthetics
- Low voltage solutions for low light areas
- Products for stairs, floors and walls



2.2 FINISHES

ACCESSIBILITY

- A large range of products to improve the safety in buildings
- Compliance with regulations
- Resistance to traffic

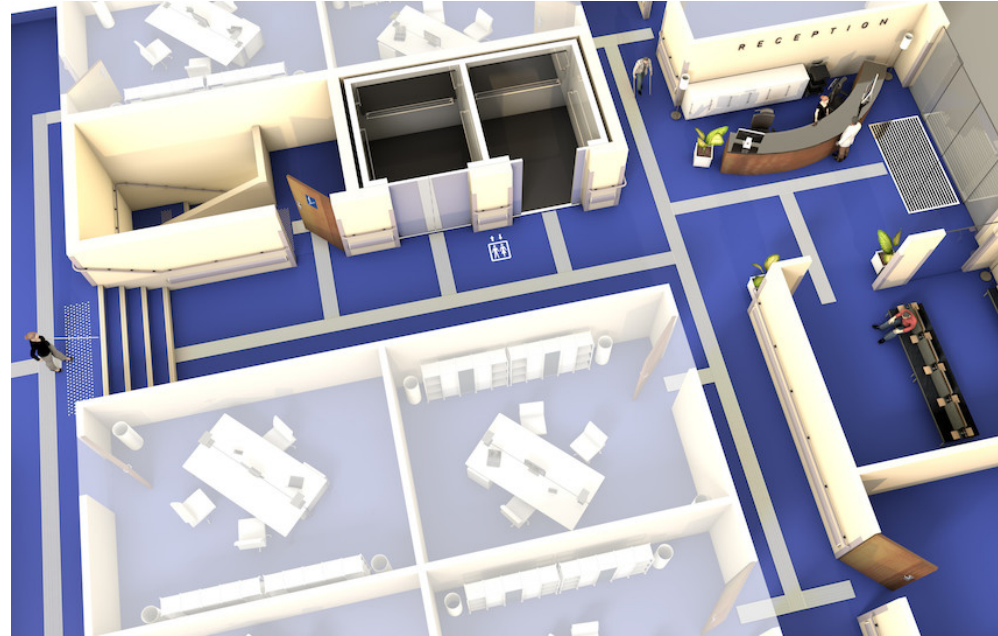

2.2 FINISHES

TOOLS

- A comprehensive range improving the ease of installation
- Exclusive and patented solutions (Safe Cap, Clean Corner System)



3 OUR DIFFERENCE



Innovation
is our DNA

3.1 INNOVATION IS OUR DNA



Innovation distinguishes between a leader and a follower



70% OF SALES

achieved with **product ranges less than three years old**



4 RESEARCH & DEVELOPMENT

centers dedicated to **product innovation**



140 ENGINEERS

for new and better **flooring solutions**



150 ACTIVE PATENTS

focus on exclusivity and **differentiation**

3.1 INNOVATIVE SOLUTIONS



Innovation distinguishes between a leader and a follower



UNIQUE VERTICAL CLIC SYSTEM
for easy and fast adhesive free installation



MIPOLAM SYMBIOZ™
The first Homogeneous flooring with 100% bio based plasticizer

* Made of residues from cereals



REVOLUTIONARY SURFACE TREATMENTS
The best chemical stain resistance

3.2 HIGH-VALUE SOLUTIONS

Specialty-based solutions for demanding applications

DEDICATED
PRODUCTS FOR
HIGH-
PERFORMING
USERS



Sport floors for the Olympic Games

SERVICE-DRIVEN
SOLUTIONS FOR
TECHNICAL
APPLICATIONS



Pre-cut self-adhesive floors for fast-track installations in buses

SPECIFIC
SOLUTIONS
FOR **COMPLEX**
ENVIRONMENTS



Comprehensive product and service solutions for cleanrooms in life science labs

INTEGRATED
HIGH-TECH
COMPONENTS



Smart floors with integrated sensors for aged care facilities

3.3 HIGH-VALUE SERVICES

Creative Services for an optimized customer experience

**CUSTOMIZATION
ON DEMAND**



WEB SERVICES

VIRTUAL LIBRARY
INTERIOR DESIGNER
BIM

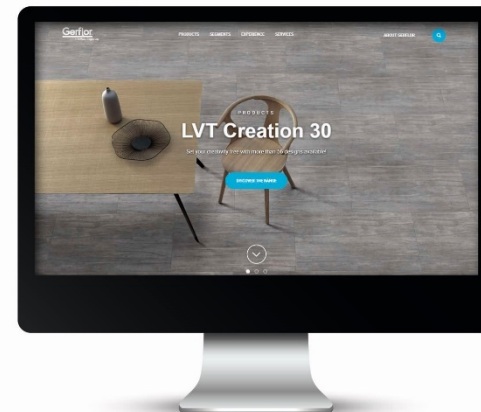

**TECHNICAL
ASSISTANCE
&
TRAINING**



**LOGISTIC
SERVICES**

QUICK SHIP
SOLUTIONS,
STOCKING PROGRAM



3.4 SUSTAINABILITY: LESS SPEAKING FOR MORE ACTIONS !



Not only do we meet standards and market requirements, we want to go further



COMPOSITION

- **100% REACH compliant**
- FREE of formaldehyde, heavy metals and solvents



RECYCLED CONTENT

- **25% aver. recycled content**
- 100% REACH compliant
- Recycled content



LCA

- **Eco-designed** according to a product specific Life Cycle Analysis.
- **ISO 14001** and **ISO 50001** certified sites.
- Contribution to **Green Building Schemes** (LEED, HQE, BREEAM...).



INDOOR AIR QUALITY

- **TVOC emissions 10 times better than norms requirements**
- Floorscore & M1 certified
- Comply with AgBB protocol
- No formaldehyde emission



INSTALLATION

Innovative **adhesive free** installation systems



RECYCLABILITY

- **100% recyclable product**

3.4 SUSTAINABILITY: RECYCLING CHAIN



Gerflor has established an efficient logistic model to collect and recycle waste



Example – Waste collection process from customer jobsite (France & Benelux) to Gerflor manufacturing plant - 3,000 t / year - Partnership with Paprec

3.5 DESIGN AND COLORS THAT SET THE TRENDS



Before talking about technical features, our **first expertise** is to **offer a design**



reddot award 2016 winner

WELCOME TO GERFLOR

DESIGN
FLOORING SOLUTIONS
CUSTOMER **WALL**
INNOVATION SEGMENTS
SPECIFIC **VALUES** SPECIALTIES
GLOBAL SUSTAINABILITY
FINISHES
GROWTH